

NSP12N3
NSP16N3
NSP12N3R
NSP16N3S
NSP16N3SR



**DEPENDABLE
PRODUCTIVITY**

SPECIFICATIONS

PEDESTRIAN AND FOLDING PLATFORM STACKER TRUCKS 24V, 1.2 - 1.6 TONS



YOUR PERFECT SHORT SHUTTLE PARTNER

THIS RANGE OF STACKERS, INCORPORATING ALL THE LATEST TECHNOLOGY, IS DESIGNED FOR SHORT SHUTTLE APPLICATIONS AND STACKING UP TO 5.4 METRES. WITH A WIDE CHOICE OF PEDESTRIAN AND FOLD-DOWN PLATFORM MODELS, YOU WILL FIND A RELIABLE AND PRODUCTIVE WORKHORSE FOR VIRTUALLY ANY WAREHOUSE.



Energy-saving programmable drive options, robust construction and high resistance to water and dirt reduce running costs and boost productivity. Maintenance needs are minimized by an integrated drive and lift system, with fewer components, and quick access to all major truck parts.



Smooth and precise control characteristics and a comfortable operating position, with a user-friendly tiller arm and excellent visibility through the mast, help to ensure a satisfying user experience. Height-adjustable castor wheels and high-strength masts help to maximize stability.



Models with a small fold-down platform are available at 1.2 and 1.6 ton capacities to take the legwork out of longer distances.



LOWER COST OF OWNERSHIP

- Latest AC technology keeps energy consumption and maintenance costs in control.
- Sturdy chassis construction and endurance-tested forks provide enhanced robustness and reliability even in some of the toughest conditions.
- Closed chassis and waterproof electrics resist moisture, dirt and corrosion - increasing uptime, cutting maintenance costs and prolonging truck life.
- Easy access to critical truck components allows faster fault diagnosis and speedier maintenance, squeezing downtime even more.
- Integrated drive and lift system features fewer components than previous models, reducing scope of maintenance.
- Closed compartment with steel cover protects battery against impact, helping to prolong battery life.
- Standard battery size allows interchangeability with other brands.

UNMATCHED PRODUCTIVITY

- AC motor allows for precise drive control, helping to improve maneuverability.
- Standard LCD display offers clear information on truck and battery condition.
- Ergonomic tiller arm helps keep operators fresh with comfortable, easy-to-use controls.
- Excellent drive and traction characteristics suit intensive work over short and medium distances.
- Distance of the fork support wheels from the rear frame has been optimized for increased stability.
- Advanced programmable controller lets users prioritize between faster performance and smoother handling with lower energy consumption, prolonging shift life.
- Tapered fork tips make for accurate and effortless pallet entry, speeding up handling cycles and preventing pallet or load damage.
- Truck can be driven with tiller arm in vertical position in ultra-low-speed 'tortoise' mode to maximize maneuverability in tight spaces.
- Narrower truck body makes handling operations in confined areas much easier.
- N3R models feature fold-down driver platform that prevents operator fatigue over longer distances.
- N3R models' folding platform stays down when lowered, saving time when operators get back on.
- NSP16N3 and N3R models fitted with the optional side stabilizers achieve greater lifting capacity at height.
- N3S straddle models allow wider loads and bottom-boarded pallets to be handled with ease.

ERGONOMICS

- Latest tiller arm design provides comfortable operating position.
- Large lift and lower levers allow for easy, one-handed control, even with gloves.
- High-strength masts help reduce load movement to a minimum.
- Slim mast profiles and hydraulic hose arrangements make for excellent forward visibility.
- Super-quiet oil-filled transmission helps keep noise levels low.
- Height-adjustable castor wheel helps to eliminate play and helps to raise load stability.



STANDARD EQUIPMENT AND OPTIONS

	NSP12N3	NSP16N3	NSP12N3R	NSP16N3S	NSP16N3SR
GENERAL					
LED discharge indicator, no hour meter	●	●	●	●	●
PIN code login 4 codes	○	○	○	○	○
Electric on/off valve for lifting and lowering, controlled by rocker switch on tiller head	●	●	●	●	●
Polyurethane drive wheel	●	●	●	●	●
Single load wheels polyurethane	●	—	—	—	—
Tandem load wheels polyurethane	○	●	●	●	●
Adjustable width between straddle load legs; 900mm - 1300mm	—	—	—	●	●
Sideways battery change (250Ah battery only)	○	○	○	○	○
ENVIRONMENT					
Cold store design, 0°C to -35°C	○	○	○	○	○
DRIVE AND LIFT CONTROLS					
Tiller up drive	●	●	●	●	●
WHEEL OPTIONS					
Polyurethane traction and load wheels	●	●	●	●	●
Power friction traction wheel	○	○	○	○	○
OTHER OPTIONS					
Speed reduction 0,5km/h above 1000mm lift, duplex and triplex masts without free lift	○	○	○	○	○
Speed reduction 0,5km/h above free lift, duplex and triplex masts with free lift	○	○	○	○	○
Side Stabilizers	—	○	—	—	—
Built-in charger, 30A	○	○	○	○	—
Key switch	●	●	●	●	●
Special RAL color	○	○	○	○	○
Load backrest	○	○	○	○	○
Accessory rack	○	○	○	○	○
List bracket, A4 size	○	○	○	○	○

Characteristics			Cat Lift Trucks	Cat Lift Trucks
1.1	Manufacturer		NSP12N3	NSP16N3
1.2	Manufacturer's model designation		Battery	Battery
1.3	Power source		Pedestrian	Pedestrian
1.4	Operator type			
1.5	Load capacity	Q (kg)	1200	1600
1.6	Load center distance	c (mm)	600	600
1.8	Load wheel axle to fork face (forks lowered)	x (mm)	750	750
1.9	Wheelbase	y (mm)	1330	1330
Weight				
2.1b	Truck weight without load, with maximum battery weight	kg	1020	1020
2.2	Axle loadings with nominal load & maximum battery weight, drive / load side	kg	810 / 1410	870 / 1755
2.3	Axle loadings without load & with maximum battery weight, drive / load side	kg	730 / 295	730 / 295
Wheels, Drive Train				
3.1	Tires: PT = Power Thane, Vul = Vulkollan, P = Polyurethane, N = Nylon, R = Rubber drive / load side		Vul / Vul	Vul / Vul
3.2	Tire dimensions, drive side	(mm)	230 x 70	230 x 70
3.3	Tire dimensions, load side	(mm)	85 x 90	85 x 75
3.4	Castor wheel dimensions (diameter x width)	(mm)	125 x 60	125 x 60
3.5	Number of wheels, load / drive side (x = driven)		1 + 1x / 2	1 + 1x / 4
3.6	Track width (center of tires), drive side	b10 (mm)	515	515
3.7	Track width (center of tires), load side	b11 (mm)	385	385
Dimensions				
4.2b	Height	h1 (mm)	see tables	see tables
4.3	Free lift	h2 (mm)	see tables	see tables
4.4	Lift height	h3 (mm)	see tables	see tables
4.5	Height with mast extended	h4 (mm)	see tables	see tables
4.9	Height of tiller arm / steering console (min/max)	h14 (mm)	865 / 1420	865 / 1420
4.15	Fork height, fully lowered	h13 (mm)	90	90
4.19	Overall length	l1 (mm)	1900 ^a	1900
4.20	Length to fork face	l2 (mm)	750 ^a	750
4.21	Overall width	b1/b2 (mm)	800	800
4.22	Fork dimensions (thickness, width, length)	s / e / l (mm)	56 / 186 / 1150	56 / 186 / 1150
4.24	Fork carriage width	b3 (mm)	750	750
4.25	Outside width over forks (minimum / maximum)	b5 (mm)	570	570
4.32	Ground clearance at center of wheelbase, (forks lowered)	m2 (mm)	20	20
4.33c	Working aisle width (Ast) with 1000 x 1200 mm pallets, load crosswise, platform up/down	Ast (mm)	2445	2445
4.34c	Working aisle width (Ast) with 800 x 1200 mm pallets, load lengthwise, platform up/down	Ast (mm)	2374	2374
4.35	Turning radius	Wa (mm)	1572	1572
Performance				
5.1	Travel speed, with / without load	km / h	6.0 / 6.0	6.0 / 6.0
5.2	Lifting speed, with / without load	m / s	0.16 / 0.33	0.15 / 0.32
5.3	Lowering speed, with / without load	m / s	0.46 / 0.35	0.48 / 0.34
5.8	Maximum gradeability with / without load	%	8 / 15	8 / 15
5.10	Service brakes (mechanical / hydraulic / electric / pneumatic)			
Electric motors				
6.1	Drive motor capacity (60 min. short duty)	kW	1.0	1.0
6.2	Lift motor output at 15% duty factor	kW	2.2	3.2
6.4	Battery voltage/capacity at 5-hour discharge	V / Ah	24 / 250	24 / 250 - 375
6.5	Battery weight	kg	210	210
6.6a	Energy consumption according to EN16796	kWh / h	0.76	0.77
Miscellaneous				
8.1	Type of drive control		Electric	Electric
10.7	Level of noise at the ear level of the driver according to EN 12 053:2001 and EN ISO 4871 in work LpAZ	dB (A)	64	
10.7.3	Hand-arm vibration (EN 13 059:2002)		< 2.5	< 2.5

9) -64mm with 150 Ah battery

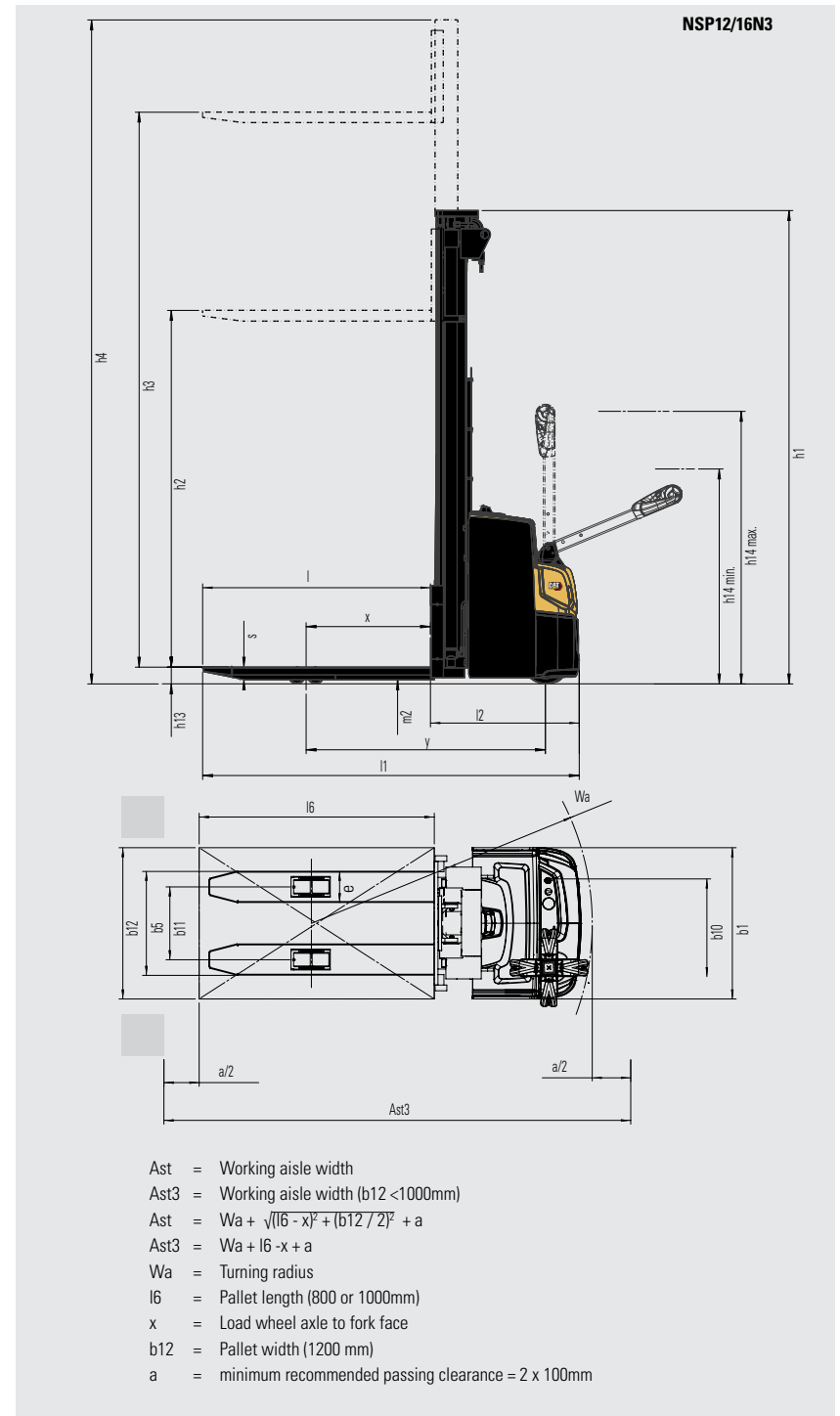

Characteristics		
1.1	Manufacturer	Cat Lift Trucks
1.2	Manufacturer's model designation	NSP12N3R
1.3	Power source	Battery
1.4	Operator type	Pedestrian / Stand-on
1.5	Load capacity	Q (kg) 1200
1.6	Load center distance	c (mm) 600
1.8	Load wheel axle to fork face (forks lowered)	x (mm) 750
1.9	Wheelbase	y (mm) 1330
Weight		
2.1b	Truck weight without load, with maximum battery weight	kg 1100
2.2	Axle loadings with nominal load & maximum battery weight, drive / load side	kg 840 / 1400
2.3	Axle loadings without load & with maximum battery weight, drive / load side	kg 860 / 320
Wheels, Drive Train		
3.1	Tires: PT = Power Thane, Vul = Vulkollan, P = Polyurethane, N = Nylon, R = Rubber drive / load side	Vul / Vul
3.2	Tire dimensions, drive side	(mm) 230 x 70
3.3	Tire dimensions, load side	(mm) 85 x 90
3.4	Castor wheel dimensions (diameter x width)	(mm) 125 x 60
3.5	Number of wheels, load / drive side (x = driven)	1 + 1 x / 2
3.6	Track width (center of tires), drive side	b10 (mm) 515
3.7	Track width (center of tires), load side	b11 (mm) 385
Dimensions		
4.2b	Height	h1 (mm) see tables
4.3	Free lift	h2 (mm) see tables
4.4	Lift height	h3 (mm) see tables
4.5	Height with mast extended	h4 (mm) see tables
4.9	Height of tiller arm / steering console (min/max)	h14 (mm) 1155 / 1550
4.15	Fork height, fully lowered	h13 (mm) 90
4.19	Overall length	l1 (mm) 2020 / 2500
4.20	Length to fork face	l2 (mm) 870 / 1350
4.21	Overall width	b1/b2 (mm) 800
4.22	Fork dimensions (thickness, width, length)	s / e / l (mm) 56 / 186 / 1150
4.24	Fork carriage width	b3 (mm) 750
4.25	Outside width over forks (minimum / maximum)	b5 (mm) 570
4.32	Ground clearance at center of wheelbase, (forks lowered)	m2 (mm) 20
4.33c	Working aisle width (Ast) with 1000 x 1200 mm pallets, load crosswise, platform up/down	Ast (mm) 2550 / 3050
4.34c	Working aisle width (Ast) with 800 x 1200 mm pallets, load lengthwise, platform up/down	Ast (mm) 2660 / 2980
4.35	Turning radius	Wa (mm) 1692 / 2172
Performance		
5.1	Travel speed, with / without load	km / h 6.0 / 6.0
5.2	Lifting speed, with / without load	m / s 0.16 / 0.33
5.3	Lowering speed, with / without load	m / s 0.46 / 0.35
5.8	Maximum gradeability with / without load	% 8 / 15
5.10	Service brakes (mechanical / hydraulic / electric / pneumatic)	
Electric motors		
6.1	Drive motor capacity (60 min. short duty)	kW 1.0
6.2	Lift motor output at 15% duty factor	kW 2.2
6.4	Battery voltage/capacity at 5-hour discharge	V / Ah 24 / 150 - 250
6.5	Battery weight	kg 210
6.6a	Energy consumption according to EN16796	kWh / h 0.77
Miscellaneous		
8.1	Type of drive control	Electric
10.7.2	Whole-body vibration (EN 13 059:2002)	0.8
10.7.3	Hand-arm vibration (EN 13 059:2002)	< 2.5

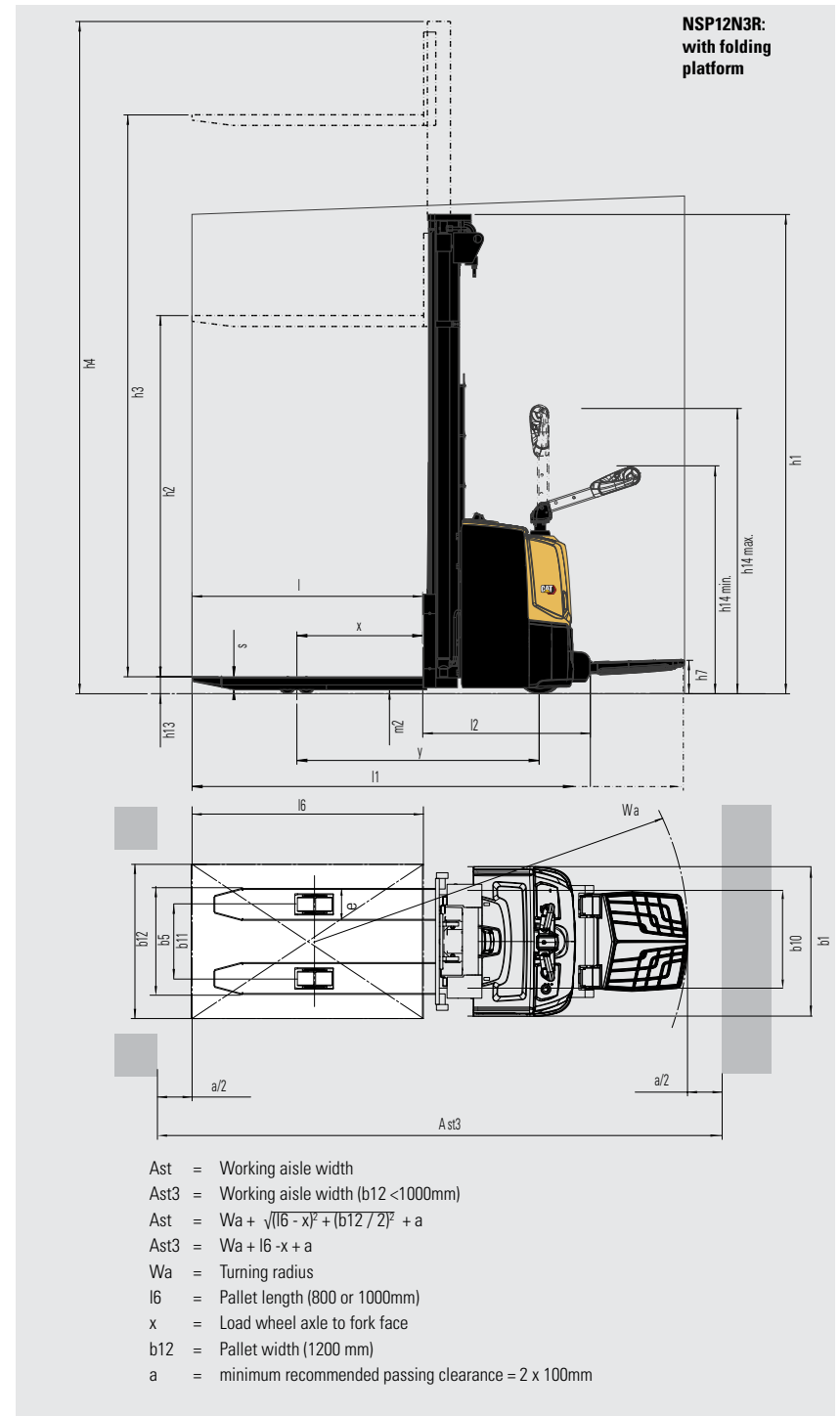

Characteristics			Cat Lift Trucks	Cat Lift Trucks
1.1	Manufacturer		NSP16N3S	NSP16N3SR
1.2	Manufacturer's model designation		Battery	Pedestrian / Stand-on
1.3	Power source		1600	1600
1.4	Operator type		600	600
1.5	Load capacity	Q (kg)	750	750
1.6	Load center distance	c (mm)	1395	1395
1.8	Load wheel axle to fork face (forks lowered)	x (mm)		
1.9	Wheelbase	y (mm)		
Weight				
2.1b	Truck weight without load, with maximum battery weight	kg	1288	1440
2.2	Axle loadings with nominal load & maximum battery weight, drive / load side	kg	1045 / 1870	1215 / 1985
2.3	Axle loadings without load & with maximum battery weight, drive / load side	kg	892 / 396	1020 / 420
Wheels, Drive Train				
3.1	Tires: PT = Power Thane, Vul = Vulkollan, P = Polyurethane, N = Nylon, R = Rubber drive / load side		Vul / Vul	Vul / Vul
3.2	Tire dimensions, drive side	(mm)	230 x 70	230 x 70
3.3	Tire dimensions, load side	(mm)	85 x 75	85 x 75
3.4	Castor wheel dimensions (diameter x width)	(mm)	125 x 60	125 x 60
3.5	Number of wheels, load / drive side (x = driven)		1 + 1 x / 4	1 + 1 x / 4
3.6	Track width (center of tires), drive side	b10 (mm)	515	515
3.7	Track width (center of tires), load side	b11 (mm)	1025-1425	1025-1425
Dimensions				
4.2b	Height	h1 (mm)	see tables	see tables
4.3	Free lift	h2 (mm)	see tables	see tables
4.4	Lift height	h3 (mm)	see tables	see tables
4.5	Height with mast extended	h4 (mm)	see tables	see tables
4.9	Height of tiller arm / steering console (min/max)	h14 (mm)	865 / 1420	1155 / 1550
4.15	Fork height, fully lowered	h13 (mm)	85	85
4.19	Overall length	l1 (mm)	1965	2085 / 2565
4.20	Length to fork face	l2 (mm)	815	935 / 1415
4.21	Overall width	b1/b2 (mm)	800 / 1140 - 1575	800 / 1140 - 1575
4.22	Fork dimensions (thickness, width, length)	s / e / l (mm)	40 / 100 / 1150	40 / 100 / 1150
4.24	Fork carriage width	b3 (mm)	980	980
4.25	Outside width over forks (minimum / maximum)	b5 (mm)	260-900	260-900
4.26	Inner width of support legs	b4 (mm)	900-1300	900-1300
4.32	Ground clearance at center of wheelbase, (forks lowered)	m2 (mm)	20	20
4.33c	Working aisle width (Ast) with 1000 x 1200 mm pallets, load crosswise, platform up/down	Ast (mm)	2580	2690 / 3170
4.34c	Working aisle width (Ast) with 800 x 1200 mm pallets, load lengthwise, platform up/down	Ast (mm)	2580	2690 / 3170
4.35	Turning radius	Wa (mm)	1637	1757 / 2237
Performance				
5.1	Travel speed, with / without load	km / h	6.0 / 6.0	6.0 / 6.0
5.2	Lifting speed, with / without load	m / s	0.15 / 0.32	0.15 / 0.32
5.3	Lowering speed, with / without load	m / s	0.43 / 0.34	0.5 / 0.34
5.8	Maximum gradeability with / without load	%	8 / 15	8 / 15
5.10	Service brakes (mechanical / hydraulic / electric / pneumatic)			
Electric motors				
6.1	Drive motor capacity (60 min. short duty)	kW	1.0	1.0
6.2	Lift motor output at 15% duty factor	kW	3.2	3.2
6.4	Battery voltage/capacity at 5-hour discharge	V / Ah	24 / 250 - 375	24 / 250 - 375
6.5	Battery weight	kg	210	210
6.6a	Energy consumption according to EN16796	kWh / h	0.77	0.78
Miscellaneous			Electric	Electric
8.1	Type of drive control	dB (A)		
10.7.2	Whole-body vibration (EN 13 059:2002)		-	0.8
10.7.3	Hand-arm vibration (EN 13 059:2002)		< 2.5	< 2.5

- Ast = Working aisle width
- Ast3 = Working aisle width (b12 < 1000mm)
- Ast = $Wa + \sqrt{(l6 - x)^2 + (b12 / 2)^2} + a$
- Ast3 = $Wa + l6 - x + a$
- Wa = Turning radius
- l6 = Pallet length (800 or 1000mm)
- x = Load wheel axle to fork face
- b12 = Pallet width (1200 mm)
- a = minimum recommended passing clearance = 2 x 100mm

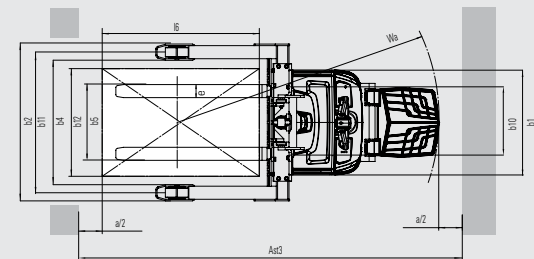
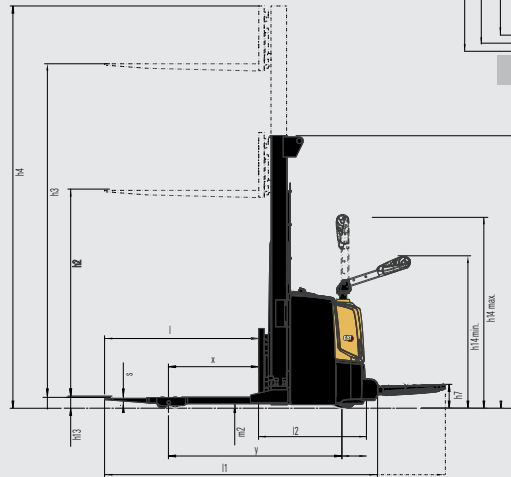
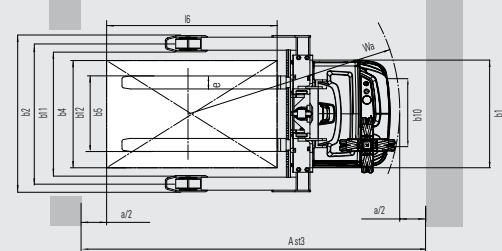
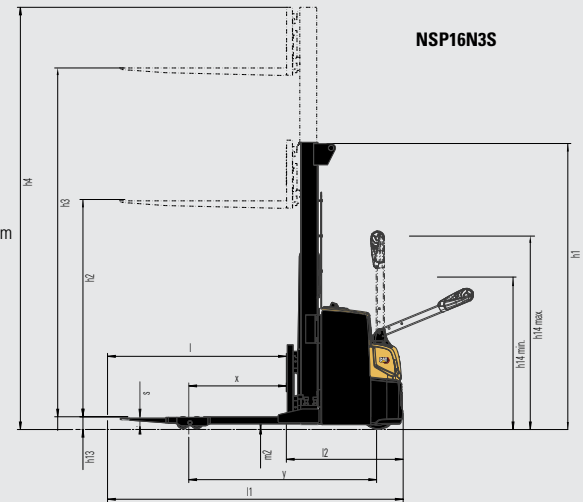

NSP16N3SR:
with folding platform

NSP12/ 16N3 / NSP12N3R				
Mast Type	h3+h13	h1	h4	h2+h13
	mm	mm	mm	mm
Simplex	1500	1950	1950	1500
	2500	1835	3000	200
	2900	2035	3400	200
	3300	2235	3800	200
	3600	2385	4100	200
	4300	2735	4800	200
Duplex Free Lift	2500	1775	2940	1355
	2900	1975	3340	1555
	3300	2235	3800	1755
	3600	2385	4100	1905
	4300	2735	4800	2255
Triplex	4100	1955	4640	-
	4300	2020	4840	-
	4700	2153	5240	-
	5400*	2385	5940	-
	Triplex Free Lift	4100	1955	4640
4300		2020	4840	1540
4700		2153	5240	1673
5400*		2385	5940	1905

NSP16N3S / NSP16N3SR					
Mast Type	h3+h13	h1	h4	h2+h13	
	mm	mm	mm	mm	
Simplex	1500	2030	2030	1500	
	2500	1915	3080	195	
	2900	2115	3480	195	
	3300	2315	3880	195	
	3600	2465	4180	195	
	4300	2815	4880	195	
	Duplex Free Lift	2500	1915	3080	1355
		2900	2115	3480	1555
3300		2315	3880	1755	
3600		2465	4180	1905	
4300		2815	4880	2255	
Triplex	4100	2035	4720	-	
	4300	2100	4920	-	
	4700	2233	5320	-	
	5400	2465	6020	-	
	Triplex Free Lift	4100	2035	4720	1475
4300		2100	4920	1540	
4700		2233	5320	1753	
5400		2465	6020	1905	

Mast Performance and Capacity

- S = Simplex
- DS = Duplex with clear view mast
- DEV = Duplex with full free lift
- TR = Triplex with clear view mast
- TREV = Triplex with full free lift
- h3+h13 = Lifting height
- h1 = Lowered mast height
- h4 = Raised mast height
- h2+h13 = Free lift



WESC2218(06/22) © 2022 MLE B.V. (registration no. 33274459), © 2026 Logisnext Americas Inc. CAT, CATERPILLAR, LET'S DO THE WORK, their respective logos, "Caterpillar Corporate Yellow", the "Power Edge", and Cat "Modern Hex" trade dress as well as corporate and product identity used herein, are trademarks of Caterpillar used under license and may not be used without permission from Caterpillar. Some products may be shown with optional equipment.

NOTE: Performance specifications may vary depending on standard manufacturing tolerances, vehicle condition, types of tires, floor or surface conditions, applications, or operating environment. Trucks may be shown with non-standard options. Specific performance requirements and locally available configurations should be discussed with your Cat lift trucks Dealer. Cat Lift Trucks follows a policy of continual product improvement. For this reason, some materials, options and specifications could change without notice.

