

NTR30N2
NTR50N2

A yellow CAT tow truck is the central focus, positioned in a factory or warehouse environment. Two workers are present: one in a green safety vest and glasses stands near the truck's controls, while another in a grey hoodie and cap stands to the right, holding a white object. The background shows industrial equipment, including blue pallet racks and yellow overhead structures. The CAT logo is prominently displayed on the side of the truck.

**CHOOSE COMFORT
AND EFFECTIVENESS**

PRELIMINARY SPECIFICATIONS
TOW TRUCK, 24V, 3.0 - 5.0 TONS



EFFECTIVE OPERATORS AND EFFICIENT LOGISTICS

CAT® N2-GENERATION TOW TRUCKS BOOST BOTH MACHINE AND OPERATOR EFFECTIVENESS, THANKS TO MARKET-EXCELLENT ENERGY EFFICIENCY, CONTROL AND COMFORT. THEIR COMPETITIVE ADVANTAGES ARE BASED LARGELY ON CLEVER DESIGNS AND INTELLIGENT SYSTEMS DEVELOPED AND PROVEN IN THE ENERGIZING NO-N2 LOW-LEVEL ORDER PICKER RANGE.



These powerful 3-ton and 5-ton capacity tow trucks feature smart technology which builds on the Cat® Responsive Drive System (RDS). Adaptive steering, intelligent curve control and automatic optimization of traction, acceleration and braking ensure smooth, precise and enjoyable driving.



For high comfort, low fatigue and maximum time efficiency, the spacious operator compartment has a low step height and offers unobstructed walk-through and on-off access. A vibration-dampening, triple-suspension floor and an ergonomic backrest add further comfort.



Walk-beside operation, giving a clearer view of the trailer, is especially useful when maneuvering to couple or uncouple trailers. It also allows easy short movements of the truck. From a walking position, the 'flying start' function enables operators to begin acceleration before stepping aboard.



Ergonomically shaped controls, integrated into the innovative steering wheel, are easily reached by the operator without releasing his or her grip. The vibration-dampened steering unit is effortless to operate with either hand and is adjustable for optimized height and angle.

LOWER COST OF OWNERSHIP

- Integrated single-unit motor and gear design adds reliability and delivers excellent energy efficiency in the market.
- Simplified one-piece main frame, with welded steel construction, is durable and robust.
- Simple and quick accessibility of systems and components for checks and servicing minimizes downtime and operating costs.
- Inspection access points in chassis enable fast checking of gears, caster wheel and drive wheel screw.
- Easy removal of motor compartment cover on front of truck (secured by two screws) gives rapid access to main service point.
- Additional removable service hatch speeds up inspection and greasing of drive unit, as well as drive wheel changes.
- Display of service hours and battery status promotes timely maintenance (and optional user interface with color display offers comprehensive information).
- PIN code access option prevents unauthorized use.

UNMATCHED PRODUCTIVITY

- Advanced steering functionality adapts rapidly to changes in operator steering behavior and travel speed, for smooth and relaxed operation.
- Unique intelligent curve control constantly adjusts steering sensitivity, cornering speed and angle limitation to maintain fluent motion, traction and balance from start to finish of turns.
- Steering control characteristics are modified when reversing to allow for driver's sideways position and one-handed operation.
- Latest advances in traction control ensure smooth, rapid acceleration and help to prevent wheelspin and related wear when driving on slippery surfaces or pulling heavy loads.
- Deceleration rate and stopping distance are easy to control for excellent positioning, and are programmable using TruckTool.
- ECO and PRO driving modes can be chosen according to the operator and application, and customized settings can be applied to meet more specific requirements.
- Walk-beside operation can be controlled via the steering wheel to improve view of trailer, maneuver when coupling and uncoupling, and make short movements (optional side-mounted controls are available).
- 'Flying start' function allows operator to begin acceleration from walk-beside position before stepping onto the presence-detecting floor mat for quicker drive start.
- Spacious and unobstructed operator compartment, with non-slip mat and low step height ensures quick walk-through access.

- Simple battery access, connection and locking mechanisms allow exchanges in seconds, for minimal downtime.
- Different coupling solutions available; standard manual or optional automatic trailer coupling which instantly locks the truck and trailer once they are in the right position, while an additional manual decoupling option enables release without leaving the operator compartment.
- Connector options enable use of trailers with hydraulic or electric functions for easier and faster handling.

ERGONOMICS

- High-comfort, triple-suspension floor offers floating structure to dampen shocks and vibrations, sideways dampening to relax knees and ankles, and thick state-of-the-art matting to reduce microvibration.
- Angled footrest minimizes strain for seated (see options) and tall operators.
- Optimized backrest shape and height give maximum walk-through access width at hip level, easy passage for operators carrying goods, and a comfortable leaning position during turns.
- Innovative steering wheel, with vibration damping, is effortless to operate with either hand and can be adjusted for height and angle to maximize comfort.
- Ergonomically shaped accelerator triggers and other controls, integrated into steering wheel, are easy to reach for the operator without releasing grip.
- Top-of-steering-wheel hand positioning enables comfortable and controlled reversing with reduced twisting of shoulders and wrists.
- Regenerative braking, optimized to eliminate swaying effect at full stop, combines with ramp hold function and anti-lock brakes to provide smooth operation, confidence and comfort in virtually any condition.
- Additional awareness features (optional) include warning devices – driving light, strobe, blue spot or programmable alarm – as well as wide side mirrors for use when towed loads are wider than the truck.



STANDARD EQUIPMENT AND OPTIONS

	NTR30N2	NTR50N2
GENERAL		
Multifunctional steering wheel (electric 200°)	●	●
Power ON/OFF via Key switch	●	●
Hour meter & BDI	●	●
ECO/PRO mode	●	●
Maximum drive speed 13 km/h (without load)	●	●
Drive speed reduction in curves	●	●
Maximum drive speed adjusted according to load weight	●	●
Floor mat as dead man's pedal	●	●
Crane battery change	●	●
Polyurethane wheels	●	●
Suspended operator's platform	●	●
Ramp hold	●	●
Automatic parking brake	●	●
Power source – Lead-acid battery	●	●
TRAILER COUPLING		
Manually operated plug coupling, pin diameter 25mm	●	●
Manually operated plug coupling, pin diameter 22mm	○	○
Automatic coupling, pin diameter 25mm	○	○
Automatic coupling with ergonomic unlocking handle, pin diameter 25mm	○	○
TRAILER INTERFACE		
Electrical 4-pin Trailer socket connection of trailer	○	○
Electrical 7-pin Trailer socket connection of trailer	○	○
Auxiliary hydraulics for hydraulic coupling of trailer	○	○
ENVIRONMENT		
Cold store design, 0C° to -35C°	○	○
DRIVE CONTROLS		
Walk beside drive button in backrest, FWD/BWD	○	○
AWARENESS		
Blue point safety light towards driving direction (forks trailing)	○	○
Driving light towards driving direction (forks trailing)	○	○
Rear working light	○	○
Wide rear view mirrors	○	○
Warning strobe, yellow	○	○
Drive alarm (programmable)	○	○
Fire extinguisher	○	○
WHEEL OPTIONS		
Polyurethane traction and load wheels	●	●
Power friction traction wheel	○	○
Solid rubber traction wheel	○	○
Treaded Super-Elastic rear wheels	○	○
Solid rubber rear wheels	○	○

● Standard ○ Option



STANDARD EQUIPMENT AND OPTIONS

	NTR30N2	NTR50N2
OUTLOOK		
Special RAL color on front machinery steel cover	○	○
OTHER OPTIONS		
PIN code access with BDI display	○	○
PIN code access with color display	○	○
Color display without PIN code access	○	○
Accessory rail in front	○	○
Scanner holder	○	○
Equipment holder (RAM mountings)	○	○
Wrapping holder	○	○
Rear grab handle on backrest	○	○
Sideways battery change	○	○
Clipboard, A4	○	○
Front storage boxes	○	○
Storage folder on bottom of the platform	○	○
Back cushion, tiltable to seat position for back & feet rest. Adjustable in height.	○	○
Power supply, 12 V	○	○
Power supply, USB 5 V	○	○
Heavy duty front nylon strip covered bumper	○	○
Raised front guard plate	○	○

● Standard ○ Option



Characteristics		
1.1	Manufacturer	
1.2	Manufacturer's model designation	
1.3	Power source	
1.4	Operator type	
1.5	Load capacity	Q (kg)
1.7	Rated drawbar pull	F (N)
1.9	Wheelbase	y (mm)
Weight		
2.1	Truck weight without load, with maximum battery weight	kg
2.3	Axle loadings without load & with maximum battery weight, drive/load side	kg
Wheels, Drive Train		
3.1	Tires: PT=Power Thane, Vul=Vulkollan, P=Polyurethane, N=Nylon, R=Rubber drive/load side	
3.2	Tire dimensions, drive side	(mm)
3.3	Tire dimensions, load side	(mm)
3.5	Number of wheels, load/drive side (x=driven)	
3.7	Track width (center of tires), load side	b11 (mm)
Dimensions		
4.2b	Height	h1 (mm)
4.8	Seat- or stand height	h7 (mm)
4.12	Coupling height	h10 (mm)
4.19	Overall length	l1 (mm)
4.21	Overall width	b1/b2 (mm)
4.25	Outside width over forks (minimum/maximum)	b5 (mm)
4.32	Ground clearance at center of wheelbase, (forks lowered)	m2 (mm)
4.35	Turning radius	Wa (mm)
Performance		
5.1	Travel speed, with/without load	km/h
5.6	Maximum drawbar pull with/without load	N
5.7	Gradeability, with/without load	%
5.10	Service brake	
Electric motors		
6.1	Drive motor capacity (60 min. short duty)	kW
6.4	Battery voltage/capacity at 5-hour discharge	V/Ah
6.5	Battery weight	kg
6.6	Energy consumption according to EN16796	kWh/h
Miscellaneous		
8.1	Type of drive control	
10.7	Level of noise at the ear level of driver according to EN 12 053:2001 and EN ISO 4871 in work LpAZ	dB(A)
10.7.1	Level of noise at the ear level of driver according to EN 12 053:2001 and EN ISO 4871, drive/lift/idle LpAZ	dB(A)
10.7.2	Whole-body vibration (EN 13 059:2002)	
10.7.3	Hand-arm vibration (EN 13 059:2002)	
10.8	Towing coupling design / DIN type, ref.	

Cat Lift Trucks	Cat Lift Trucks
NTR30N2	NTR50N2
Battery	Battery
Stand-on	Stand-on
3000	5000
600	1000
1120	1120
1106	1106
616/490	616/490
Vul/ Vul	Vul/ Vul
ø250	ø250
ø250	ø250
2/ 1x	2/ 1x
650	650
1173	1173
123	123
155**	155**
1450	1450
800	800
794	794
50	50
1306	1306
9,0/ 13,0***	7,0/ 13,0***
6 / 15	4 / 15
Electric	Electric
2.6	2.6
24/ 465-620	24/ 465-620
366-493	366-493
0.92	1.23
Stepless	Stepless
69	69
73/-/	73/-/
0.9	0.9

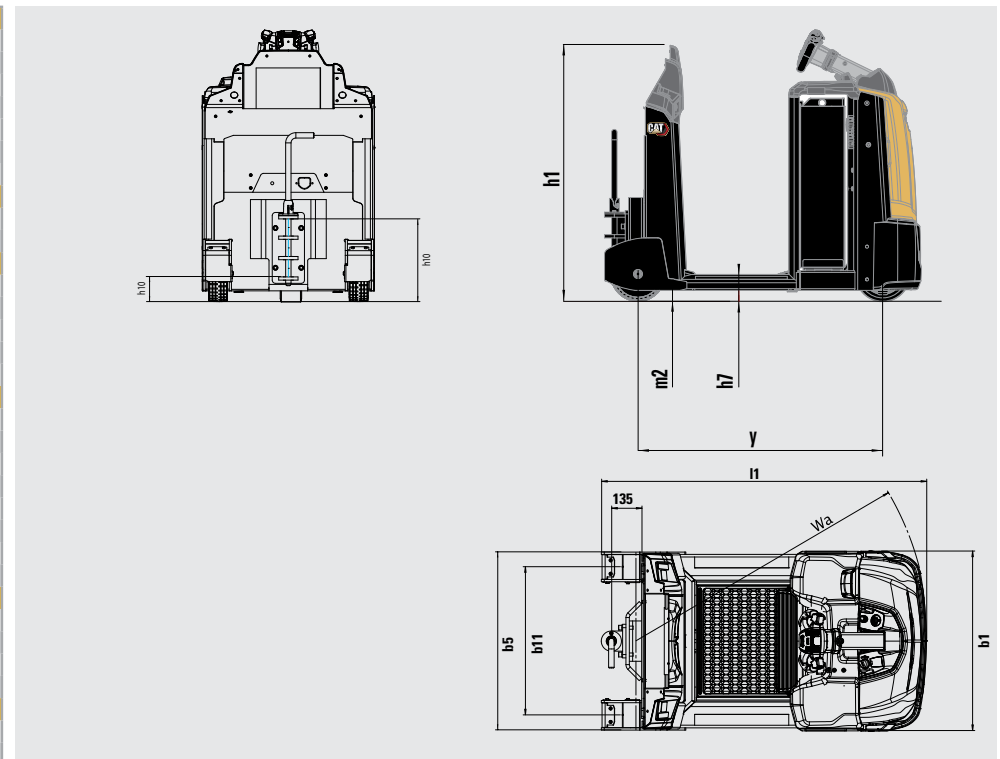

DRIVE SPEED CHART

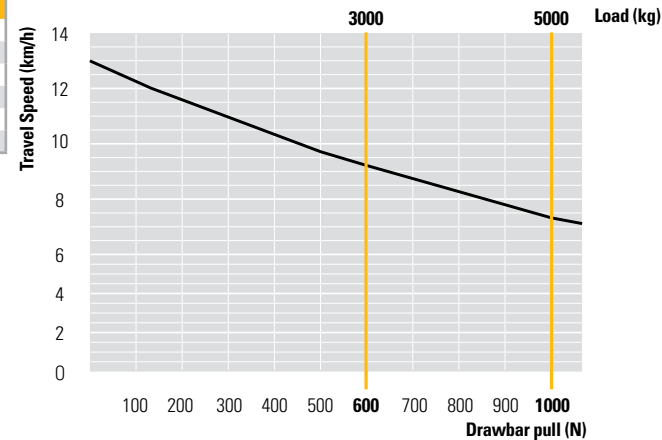

**) other coupling heights available

***) See drive speed chart

WESC2000AME(07/19) 2019 MCFE. © 2026 Logisnext Americas Inc. CAT, CATERPILLAR, LET'S DO THE WORK, their respective logos, "Caterpillar Corporate Yellow", the "Power Edge", and Cat "Modern Hex" trade dress as well as corporate and product identity used herein, are trademarks of Caterpillar used under license and may not be used without permission from Caterpillar. Some products may be shown with optional equipment.

NOTE: Performance specifications may vary depending on standard manufacturing tolerances, vehicle condition, types of tires, floor or surface conditions, applications, or operating environment. Trucks may be shown with non-standard options. Specific performance requirements and locally available configurations should be discussed with your Cat lift trucks Dealer. Cat Lift Trucks follows a policy of continual product improvement. For this reason, some materials, options and specifications could change without notice.

