



# MAXIMUM EFFICIENCY

**6,000 / 8,000 LB. CAPACITY  
END RIDERS**



# RUGGED DESIGN FOR YOUR TOUGH JOBS

## Strength Inside And Out

The heavy-duty 3-phase AC motors provide the power to run longer on one charge by using less energy per cycle. Furthermore, our 190 degree steering arc allows operators to effectively and precisely maneuver these trucks, especially in more restrictive or confined spaces.

## Exceptional Comfort For A Long Day's Work.

With a top mounted tiller handle design, the largest operator platform in its class and outstanding all-around visibility, these end riders provide exceptional comfort and minimize fatigue for the operator. These trucks are designed with easy to reach, soft switches and buttons that makes them even easier to operate. The thick, sturdy, tubular, rubber-padded intermediate grab bar also helps to provide operator stability during normal operation.

### ERGONOMIC TILLER HEAD FEATURES

- Infinitely variable travel speeds and easy lifting and lowering commands for greater control

- Soft touch, easy to reach buttons and smooth, effortless finger tip directional controls from either side

- Jog buttons allow operator to walk beside the truck and advance it without having to get on/off continuously



## Simplified Maintenance:

- Brushless AC drive motors use fewer components and require less maintenance
- One-piece two-bolt removal of cover containing major components
- "Smart" electric brake allows for longer brake life with no adjustments to be made



## Less Downtime. More Reliability.

### Optional Multi-functional LCD

- PIN numbers
- Customized performance settings
- Visual depiction of remaining battery charge.
- On-board diagnostics
- Tool-free troubleshooting

### Enclosed frame

Helps keep the debris away from major components

### IP65 rated sealed controller

allows these trucks to operate in wet rooms, coolers and freezers with temperatures down to -20°F (-28.9°C)

### Powerful 3-phase AC technology:

Brushless AC drive motors utilize fewer components, requiring less maintenance

### Thermal protection

may slow or shut down the system in case of high temperatures

### Spring-loaded disc brake system

eliminates the need for adjustments

### Large ball-bearing steering mechanism

helps to provide a smooth and easy operation

### Heavy-duty lift system

combined with a quiet, spiral beveled gear drive system, provides solid and reliable performance

### Auto-lift feature

provides a full 6 inches of clearance to help reduce pallet and load carry component damage

### Robust fork design



Local service and support



Genuine OEM parts



Custom financing packages



Factory warranty for added protection

# MORE CONFIDENCE

## Local Support You Can Count On

A Cat lift truck purchase connects you to a variety of material handling solutions, including world-class service and support from your local, trusted dealer. With trained service technicians, a diverse parts inventory and a broad selection of service options, your local dealer can help you lower costs, enhance productivity and more efficiently manage your business.

### FINANCING MADE SIMPLE

Financing your next Cat lift truck is easy with our wide range of flexible leasing and purchasing options. Whether you want to finance or lease, your local Cat lift truck dealer can help customize a package for your business.

### WHEN EVERY PART COUNTS

When buying from your local Cat lift truck dealer, you can rest assured that your genuine OEM parts are manufactured to meet original equipment criteria. Additionally, all Cat lift trucks OEM parts come with a six-month, unlimited-hours warranty.

When speed is critical, our Parts Fast Or Parts Free Guarantee\* ensures next-business-day delivery of all Cat lift trucks parts, or they're free, including freight. If your part doesn't come in by the next business day, we pay for it.

### STANDING BEHIND OUR PRODUCTS

We deliver peace of mind by helping your lift trucks stay on the job. Every new Cat lift truck is covered by a 1-year / 2,000-hours warranty that includes parts and labor, as well as components and systems. With our standard 2-year / 4,000-hours extended powertrain warranty, you'll have the confidence that only comes from owning a Cat lift truck.

\* At dealer's location.

† Programs may be subject to change without notice and may vary by region.  
Please ask your local Cat lift truck dealer for complete terms and conditions.

# Specifications

Characteristics			WR27M			WR36M		
1	Capacity at rated load center	lb kg	6,000	2,720	1	8,000	3,630	
2	Capacity at load center – distance	in mm	24	500	2	24	500	
3	Power – diesel, gasoline, LP gas, electric		24V electric			24V electric		
4	Operator type		walkie / rider			walkie rider		
5	Tire type – drive, caster / load wheels		solid rubber / poly / Dyalon® A Poly			solid rubber / poly / Dyalon® A Poly		
6	Wheels (x=driven) number drive / caster / load		1x / 2 / 2			1x / 2 / 2		
Dimensions			WR27M			WR36M		
7	Head length	in mm	42.7	1,085	7	42.7	1,085	
8	Overall truck length	in mm	78.8 / 84.8 / 90.8 / 126.8 / 138.8	2,000 / 2,155 / 2,305 / 3,220 / 3,530	8	126.8 / 138.8	2,000 / 2,155 / 2,305 / 3,220 / 3,530	
9	Chassis width	in mm	35.6	905	9	35.6	905	
10	Face of forks to center of load wheel – forks raised	in mm	24.4 / 30.4 / 36.4 / 56.5 / 56.	620 / 770 / 925 / 1,435 / 1,435	10	24.4 / 30.4 / 36.4 / 56.5 / 56.	620 / 770 / 925 / 1,435 / 1,435	
	Face of forks to center of load wheel – forks lowered	in mm	28.0 / 34.0 / 40.0 / 60.1 / 60.1	710 / 865 / 1,015 / 1,525 / 1525		28.0 / 34.0 / 40.0 / 60.1 / 60.1	710 / 865 / 1,015 / 1,525 / 1525	
11	Center of load wheel to fork tips – forks raised	in mm	11.3 / 11.3 / 11.3 / 27.2 / 39.2	290 / 290 / 290 / 690 / 995	11	11.3 / 11.3 / 11.3 / 27.2 / 39.2	290 / 290 / 290 / 690 / 995	
	Center of load wheel to fork tips – forks lowered	in mm	7.7 / 7.7 / 7.7 / 23.6 / 35.6	195 / 195 / 195 / 605 / 905		7.7 / 7.7 / 7.7 / 23.6 / 35.6	195 / 195 / 195 / 605 / 905	
12	Wheelbase – forks raised	in mm	51.6 / 57.6 / 63.6 / 83.5 / 83.5	1,310 / 1,465 / 1,615 / 2,120 / 2,120	12	51.6 / 57.6 / 63.6 / 83.5 / 83.5	1,310 / 1,465 / 1,615 / 2,120 / 2,120	
	Wheelbase – forks lowered	in mm	55.2 / 1.2 / 67.2 / 87.1 / 87.1	1,405 / 1,555 / 1,710 / 2,215 / 2,215		55.2 / 1.2 / 67.2 / 87.1 / 87.1	1,405 / 1,555 / 1,710 / 2,215 / 2,215	
13	Drive tire dimensions	in mm	10 x 5	254 x 127	13	10 x 5	254 x 127	
14	Caster wheel dimensions	in mm	5 x 2.5	127 x 64	14	5 x 2.5	127 x 64	
15	Load wheel dimensions	in mm	3.25 x 6	83 x 152	15	3.25 x 6	83 x 152	
Performance			WR27M			WR36M		
16	Travel speed – unloaded	mph km/h	9.1	14.6	16	9	14.6	
17	Travel speed – loaded	mph km/h	6.6	10.6	17	6.1	9.8	
18	Lift / lower speed – unloaded	seconds	3.6	5.1	18	3.6	5.1	
19	Lift / lower speed – loaded	seconds	5.1	4.8	19	6.1	4.7	
20	Grade clearance – forks raised with pallet	%	36.4 / 32.5 / 29.4 / 22.4 / 22.4			36.4 / 32.5 / 29.4 / 22.4 / 22.4		
21	Turning radius – standard	in mm	68.0 / 73.9 / 79.7 / 99.5 / 99.5	1,730 / 1,875 / 2,025 / 2,530 / 2,530	21	68.0 / 73.9 / 79.7 / 99.5 / 99.5	1,730 / 1,875 / 2,025 / 2,530 / 2,530	
22	Right angle stacking aisle* (40", 42", 48" load width)	in mm	78.0 / 84.0 / 90.0 / 128.0 / 140.0	1,980 / 2,130 / 2,285 / 3,230 / 3,540	22	78.0 / 84.0 / 90.0 / 128.0 / 140.0	1,980 / 2,130 / 2,285 / 3,230 / 3,540	
23	90° equal intersecting area* – 40" load length	in mm	66.2 / 69.3 / 72.4 / 83.6 / 84.7	1,685 / 1,760 / 1,840 / 2,125 / 2,150	23	66.2 / 69.3 / 72.4 / 83.6 / 84.7	1,685 / 1,760 / 1,840 / 2,125 / 2,150	
24	90° equal intersecting area* – 42" load length	in mm	67.2 / 70.3 / 73.4 / 84.6 / 85.8	1,710 / 1,785 / 1,865 / 2,150 / 2,180	24	67.2 / 70.3 / 73.4 / 84.6 / 85.8	1,710 / 1,785 / 1,865 / 2,150 / 2,180	
25	90° equal intersecting area* – 48" load length	in mm	70.3 / 73.4 / 76.2 / 87.8 / 88.9	1,785 / 1,865 / 1,945 / 2,230 / 2,260	25	70.3 / 73.4 / 76.2 / 87.8 / 88.9	1,785 / 1,865 / 1,945 / 2,230 / 2,260	
Weight			WR27M			WR36M		
26	Truck weight – no load, without battery	lb kg	1110 / 1140 / 1165 / 1305 / 1340	505 / 515 / 530 / 590 / 610	26	1110 / 1140 / 1165 / 1305 / 1340	505 / 515 / 530 / 590 / 610	
27	Battery weight – minimum	lb kg	900	410	27	900	410	
28	Battery weight – maximum	lb kg	1,500	680	28	1,500	680	
Forks			WR27M			WR36M		
29	Forks size – outside spread	in mm	27	685	29	27	685	
30	Fork height – raised	in mm	9.25	235	30	9.25	235	
31	Fork length	in mm	36 / 42 / 48 / 84 / 96	915 / 1,060 / 1,210 / 2,125 / 2,430	31	36 / 42 / 48 / 84 / 96	915 / 1,060 / 1,210 / 2,125 / 2,430	
32	Fork height – lowered	in mm	3.25	82.5	32	3.25	82.5	
33	Fork width	in mm	9.25	235	33	9.25	235	
Battery			WR27M			WR36M		
34	Compartment size* – length x width x height	in mm	31.9 x 13.25 x 32	810 x 335 x 815	34	31.9 x 13.25 x 32	810 x 335 x 815	
35	Amp Hr capacity – maximum (6-hour)	Ah	840			840		
36	Lead length – position B	in mm	20	508	36	20	508	
37	Connector	type	SB-175 Red			SB-175 Red		
38	Battery roller (optional) – height from floor (forks lowered)	in mm	7.9	200	38	7.9	200	

Call-out numbers shown in the diagram correspond to the first column of the specifications chart.

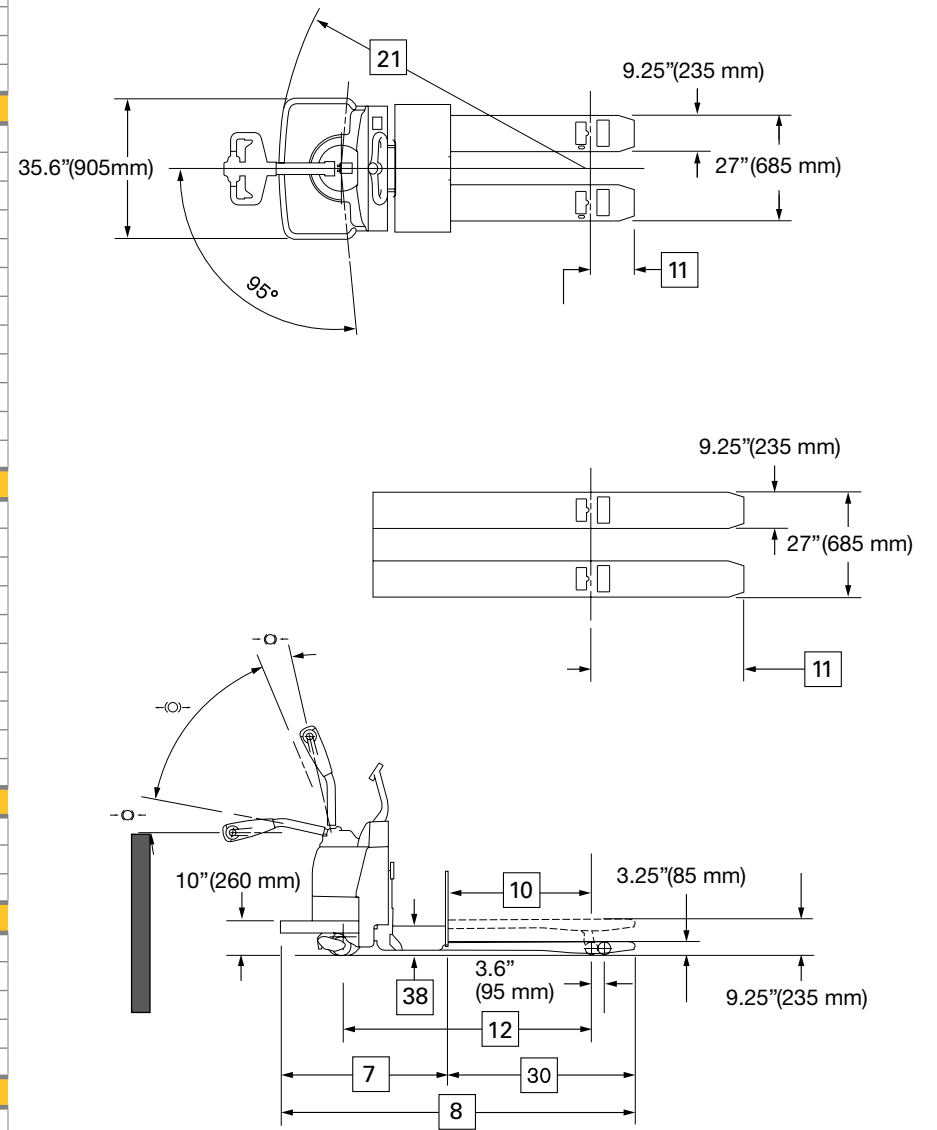

\*Battery compartment size with adjustable retainers - 30.9 x 13.25 x 32 (785 x 335 x 815); With optional rollers and side gates: 31.1 x 13.25 x 32 (790 x 335 x 815)

**NOTE:** These specifications assume the use of drive axles, tires and tilt angles specified. Maximum converted value to gradeability at maximum torque of the traction motor. Any modification to specifications, or any other combination of specifications made after the shipment of the truck, requires prior written approval from Logisnext Americas, Inc. (See ANSI/ITSDF B56.1.) Also be advised that overall operating visibility may be affected by the mast configuration and mast options of your truck. Therefore, you may need to add ancillary [auxiliary] devices or modify your operating practices. Consult your dealer for further information.

## Safety Standards

These trucks meet American National Standards Institute/Industrial Truck Standards Development Foundation, ANSI/ITSDF B56.1.

Users should be aware of, and adhere to, applicable codes and regulations regarding operator training, use, operation and maintenance of powered industrial trucks, including:

- ANSI/ITSDF B56.1.
- NFPA 505, fire safety standard for powered industrial trucks - type designations, areas of use, maintenance and operation.
- Occupational Safety and Health Administration (OSHA) regulations that may apply.

Contact your Cat lift truck dealer for further information including operator training programs and auxiliary visual and audible warning systems, fire extinguishers, etc., as available for specific user applications and requirements. Specifications, equipment, technical data, photos and illustrations based on information at time of printing and subject to change without notice. Some products may be shown with optional equipment.



**Your Cat lift truck dealer** can provide additional options and features to specialize your lift truck for your unique application. Operator training and custom financing programs are also available to help find the right fit for your business.

Helping move businesses forward – that’s how we’re built.

Note: Equipping this model with a power source (e.g. Lithium-ion, Hydrogen Fuel cell, etc.) that has not been previously approved by the factory is considered a modification. Per OSHA 1910.178 and ANSI/ITSDF B56.1, please consult with your factory representative prior to installing any non-OEM power source that has not been previously approved.

\*The product shown may be different than the actual configuration based on market requirements.

© 2026 Logisnext Americas Inc. CAT, CATERPILLAR, LET'S DOTHE WORK, their respective logos, "Caterpillar Corporate Yellow", the "Power Edge" and Cat "Modern Hex" trade dress as well as corporate and product identity used herein, are trademarks of Caterpillar used under license and may not be used without permission from Caterpillar. Some products may be shown with optional equipment.